

NPR-300

CHASSIS CAB DRAWINGS

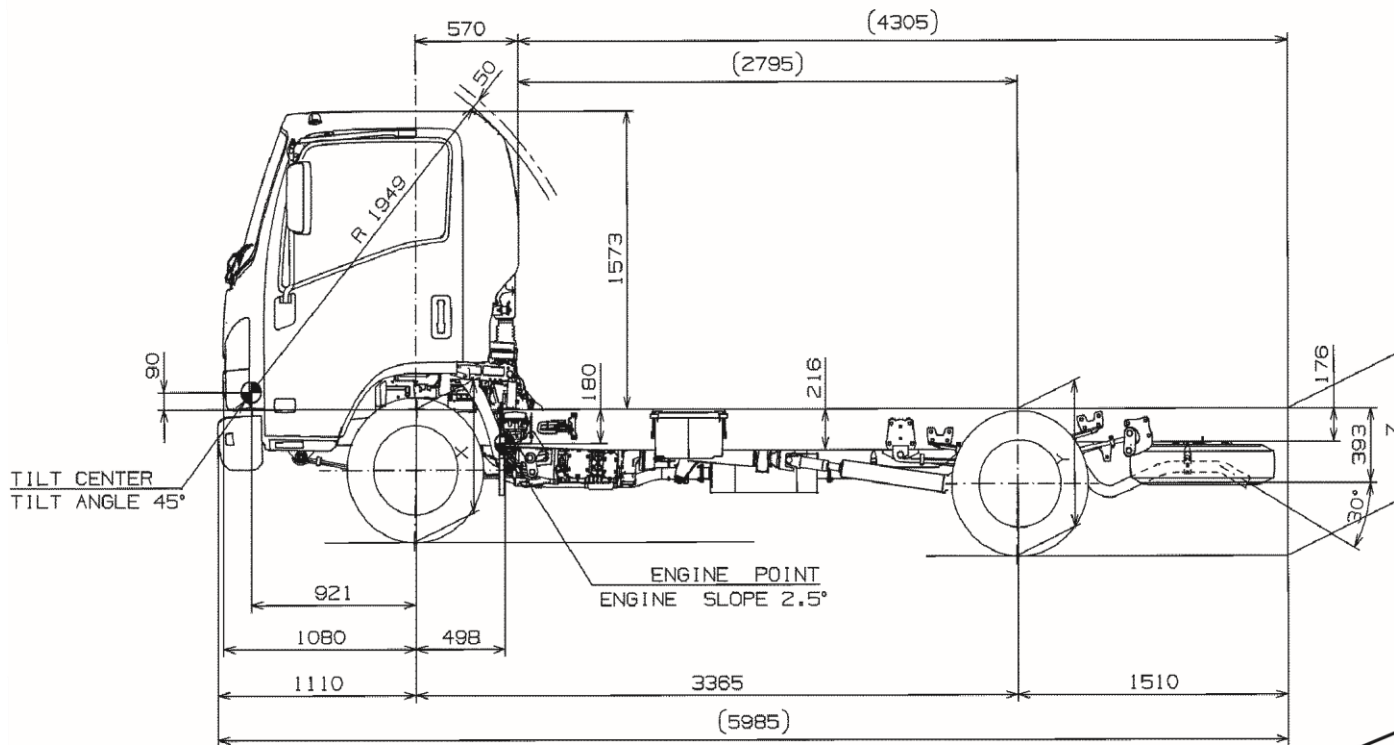
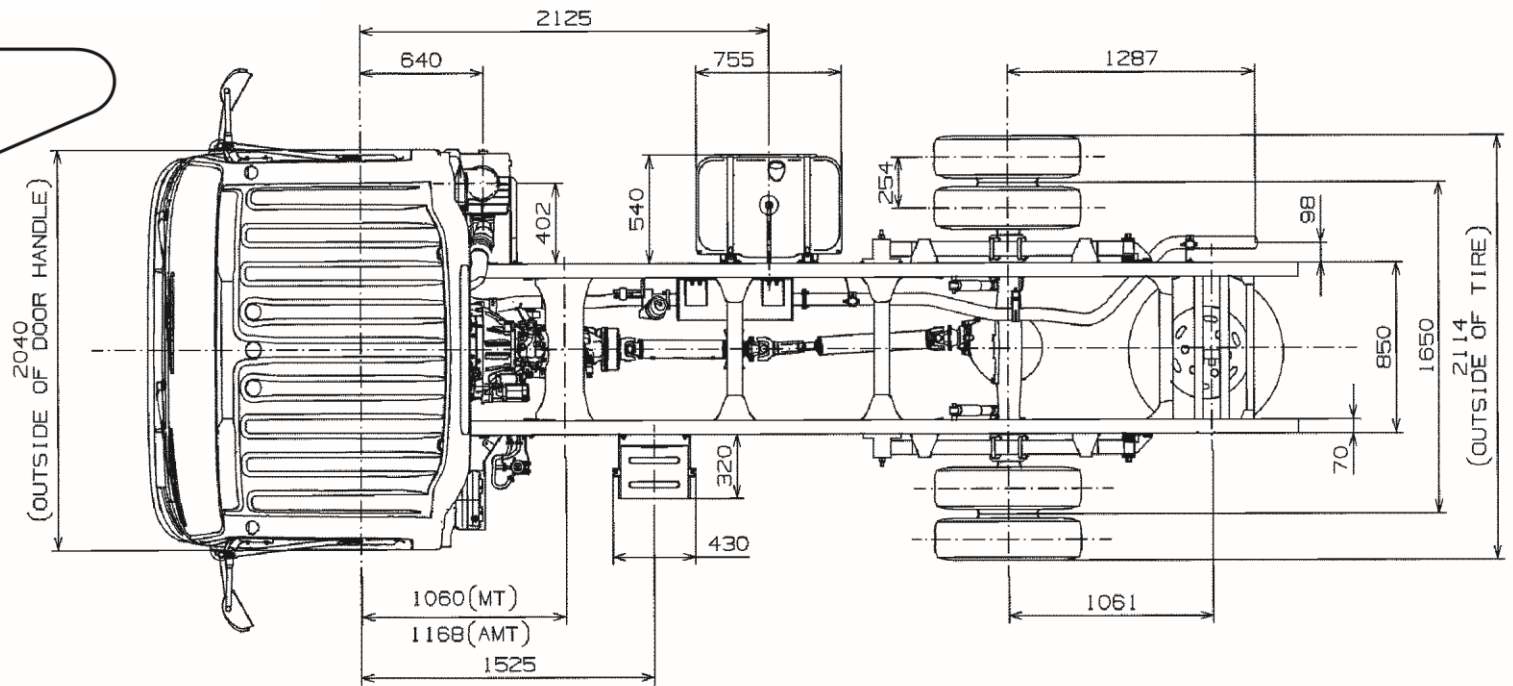

HH – REAR GROUND CLEARANCE
210mm

EH – CHASSIS REAR END HEIGHT
770mm

www.isuzu.co.za f t

ISUZU
With you, for the long run